

**Cruise speed:**  
**300 km/h**

**Range:**  
**300 km**

**Payload:**  
**4 PAX / 400 kg**



© CIIRC, Michal Postránecký

- Fully autonomous operation
- Integration with U-Space/UTM
- All weather operation
- Full VTOL capability
- Mission optimized design
- Tilt wing
- Hybrid-electric power system



Beranových 130, Prague 9  
Czech Republic  
e-mail: [uas@vzlu.cz](mailto:uas@vzlu.cz)  
[www.vzlu.cz](http://www.vzlu.cz)



# COMPLEX SOLUTIONS FOR UNMANNED AERIAL SYSTEMS



## DEVELOPMENT

- CFD calculations and simulations
- Aerodynamic multicriteria optimizations
- Flight performance and characteristics
- FEM calculations, simulations
- Topologic, strength, stiffness, and weight optimization of structures
- Multi-physical simulation
- Crash analysis and simulation
- Rotor dynamics
- Development of composite structures (incl. fire resistant and radio transparent)
- High performance propellers design
- Airborne SW/HW design

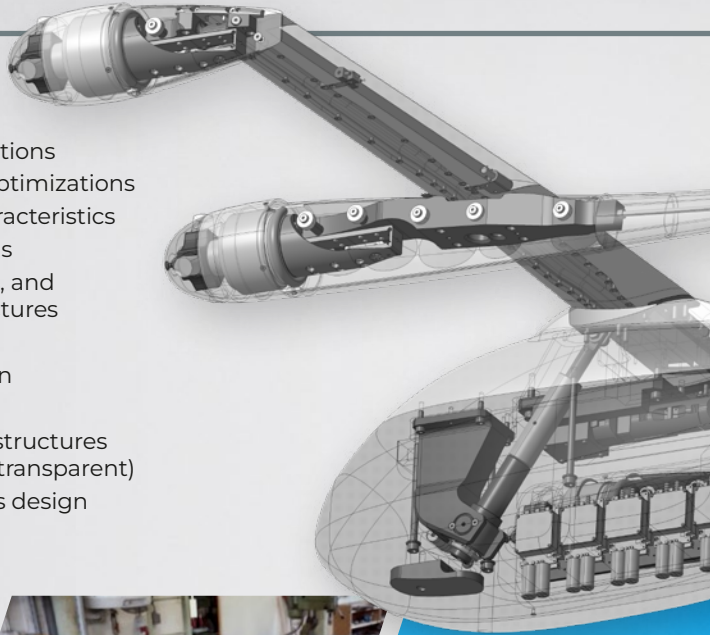

## TESTING

- Full-scale tests in wind tunnels
- Flight tests in approved polygon
- Full-scale static and fatigue tests of airframe structures (also under thermal and humidity conditions)
- Bird and hail strike tests
- Fire resistance and heatproof tests
- Material properties and metallography
- Physical characteristics of composites
- Non-destructive testing

## MANUFACTURING

- Composite airframes and structures (RTM, VARTM, RFI, autoclave, etc.)
- Fire-resistant composite structures
- Composite propellers
- Composite radomes
- Assembly and system integration

**CERTIFICATION SUPPORT**